



Corona Supplies Ltd
for all your corona needs

Unit G, Howland Road Business Park, Thame, Oxon. OX9 3GQ. UK.
Telephone: +44 (0) 1844 261779 ~ Fax: +44 (0) 1844 358187 ~ E-mail: sales@coronasupplies.co.uk

COVERED ROLL ASSEMBLY CORONA TREATER STATION



USER MANUAL

Requirements

IMPORTANT!!! Please read this information BEFORE installing and operating the equipment.

Intended Users

This manual is to be made available to all persons who are required to install, configure or service equipment described herein, or any other associated operation.

The information given is intended to highlight safety issues, EMC considerations, and to enable the user to obtain maximum benefit from the equipment.

Applications

The equipment described is intended for industrial & commercial surface treatment of various poly and non poly substrates.

Personnel

Installation, operation and maintenance of the equipment should be carried out by competent personnel. A competent person is someone who is technically qualified and familiar with all safety information and established safety practices; with the installation process, operation and maintenance of this equipment; and with all the hazards involved.

Safety

Product warnings



DANGER
HIGH VOLTAGE
RISK OF ELECTRIC SHOCK



CAUTION
REFER TO
DOCUMENTATION



DANGER
PINCH POINT
RISK OF CRUSHING



DANGER
MOVING MACHINERY
RISK OF CRUSHING



DANGER
ROTATING ROLLERS
RISK OF ENTANGLEMENT /
CRUSHING



DANGER
HOT SURFACE
RISK OF BURNS



CAUTION
OZONE CONNECTION PORT

Hazards

DANGER!!! Ignoring the following may result in injury or death.

- This equipment can endanger life by exposure to high voltages, heat and rotating machinery.
- This equipment generates an output at the radio-frequency level. Users who wear a pacemaker, or use other medical electronic devices which might be affected by radio-frequency waves, are advised to consult a physician before using this equipment.
- The equipment must be permanently earthed due to the high earth leakage current, and the treater station must be connected to an appropriate safety earth. Earth connection points are shown with the following label.

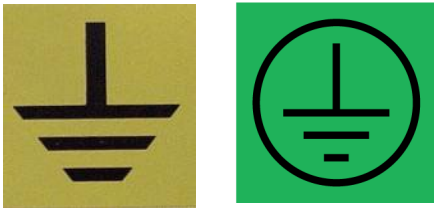

- Ensure all incoming supplies are isolated before working on the equipment. Be aware that there may be more than one supply connection to the corona power supply.
- Allow at least 1 minute for the corona power supply's capacitors to discharge to safe voltage levels (less than 50V).
- For measurements use only a meter to IEC 61010 (CAT III or higher). Always begin using the highest range. CAT I and CAT II meters must not be used on this product.
- Guards, covers & doors must NOT be removed unless the corona power supply has been switched off and the incoming supply isolated.
- During the corona treatment process a high level of heat is produced at the electrodes which will be transferred to the base roller. Before attempting any maintenance wait at least 10 minutes after switching the machine off to allow electrodes and associated parts to cool down
- Ozone generated by the corona process must be removed from the treater station by a suitable extraction system manufactured from corrosion resistant materials.
- Access Covers and doors that are regularly required to be opened for correct machine setup & cleaning are protected with a safety device which must be checked for correct operation / damage as shown as detailed in the maintenance part of this manual.

Contents

Requirements	2
Safety	3
• Product warnings	
• Hazards	
Machinery data	6
• Corona power supply	
• HT Transformer	
• Treater station	
• Optional equipment	
Introduction	7
• The corona treating process	
Installation	8
• Treater Station	
• Pneumatics	
• Electrical	
• Ozone extraction	
• Options – See APP.A	
Commissioning	16
• Air Gap Setting	
• Electrical Interlocks	
• Options – See APP.A	
Start-up	22
Maintenance	23
Warranty & aftersales service	29

APP.A: OPTIONS
APP.B: MACHINE PARTS LIST
APP.C: MACHINE DRAWINGS
APP.D: ELECTRICAL DIAGRAMS

Machinery data

THIS PAGE LEFT BLANK

Insert Machinery data here

Introduction

The corona treating process

Gases are normally very good electrical insulators or dielectrics. In the presence of a very strong electrical field a gas can be forced to break down and lose its insulating capability. During this breakdown the gas molecules begin to ionize. This enables them to provide a conductive path from one molecule to another. In a treating system the strong electrical field is generated across an air gap between the electrode assembly and the treater roll. A conductive path between these two electrodes will be completed when a sufficient quantity of gas (usually ambient room air) has become ionized. A sudden discharge across this path will now occur usually resulting in a bright flash or arc. This is very similar to a lightning flash going to earth or the arc between electrodes in a laboratory experiment. In order to prevent this arc from completely developing a solid dielectric barrier is placed in the path between the electrodes. This barrier partially interrupts the conductive path preventing a complete breakdown of the gas. Instead of a hot localized arc, a cooler diffuse glow will occur. This soft violet colored discharge indicates the incomplete breakdown of the gas and is called a corona. The material the dielectric or barrier is composed of is chosen so that enough current will flow between the electrodes and through it to sustain this corona.

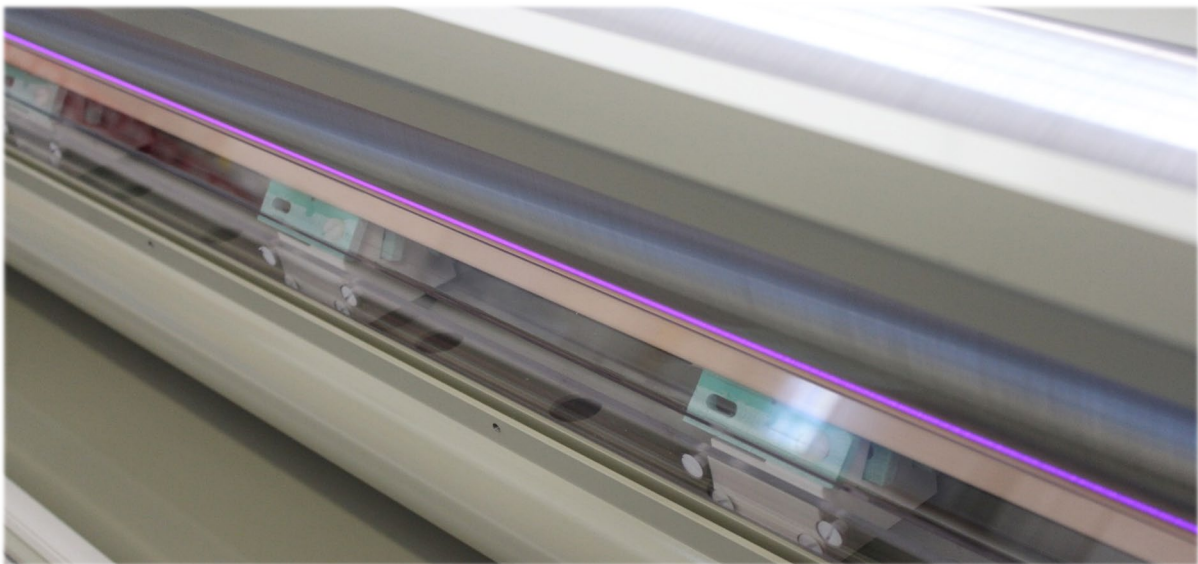

During the treatment process, the web is passed through a high voltage discharge field and is exposed to the bombardment of high-energy particles. This corona field has the potential to break polymer bonds, cause micro-pitting, and deposit an induced surface charge with extremely high levels of strong oxidizing agents onto the web. Any one of or possibly all of these processes can alter the surface characteristics of the material in a way, which enhances the surface adhesion and its ability to accept printing inks, adhesives, coatings, etc.

Installation



CAUTION!!!

Do not install this equipment in wet environments subject to high humidity.

Treater Station

Most assembly type treater stations can be mounted in any orientation, on any one of the four faces of the machine to allow the unit to be installed easily into the customers production line machine Fig.1. However it is imperative that the high voltage transformer (if fitted) is in the upright position, therefore the orientation and mounting face will have been agreed at time of order and the treater station will have been built to this design.

Location

- The treater station is designed to be located in a production line (fixed installation) with the film substrate being fed autonomously through the treater station. “Webbing up” of the treater station may be carried out manually ensuring the system has been switched off first.
- The position of the treater station on the production line will be governed by the web path and available space however, it should be positioned so that the location does not cause a hazard, including tripping, obstruction, overhead obstruction. Access for maintenance should also be considered when positioning the treater station.
- The treater station must be installed so that the film substrate is entering and exiting the treater in the correct direction. The direction of travel must be that in the event of an obstruction on the substrate (lump or splice) the electrode assembly will be pushed out of the way by the obstruction. Fig.2

1 2 3 4 5 6

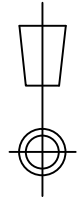

THIRD ANGLE PROJECTION
DO NOT SCALE
IF IN DOUBT ASK

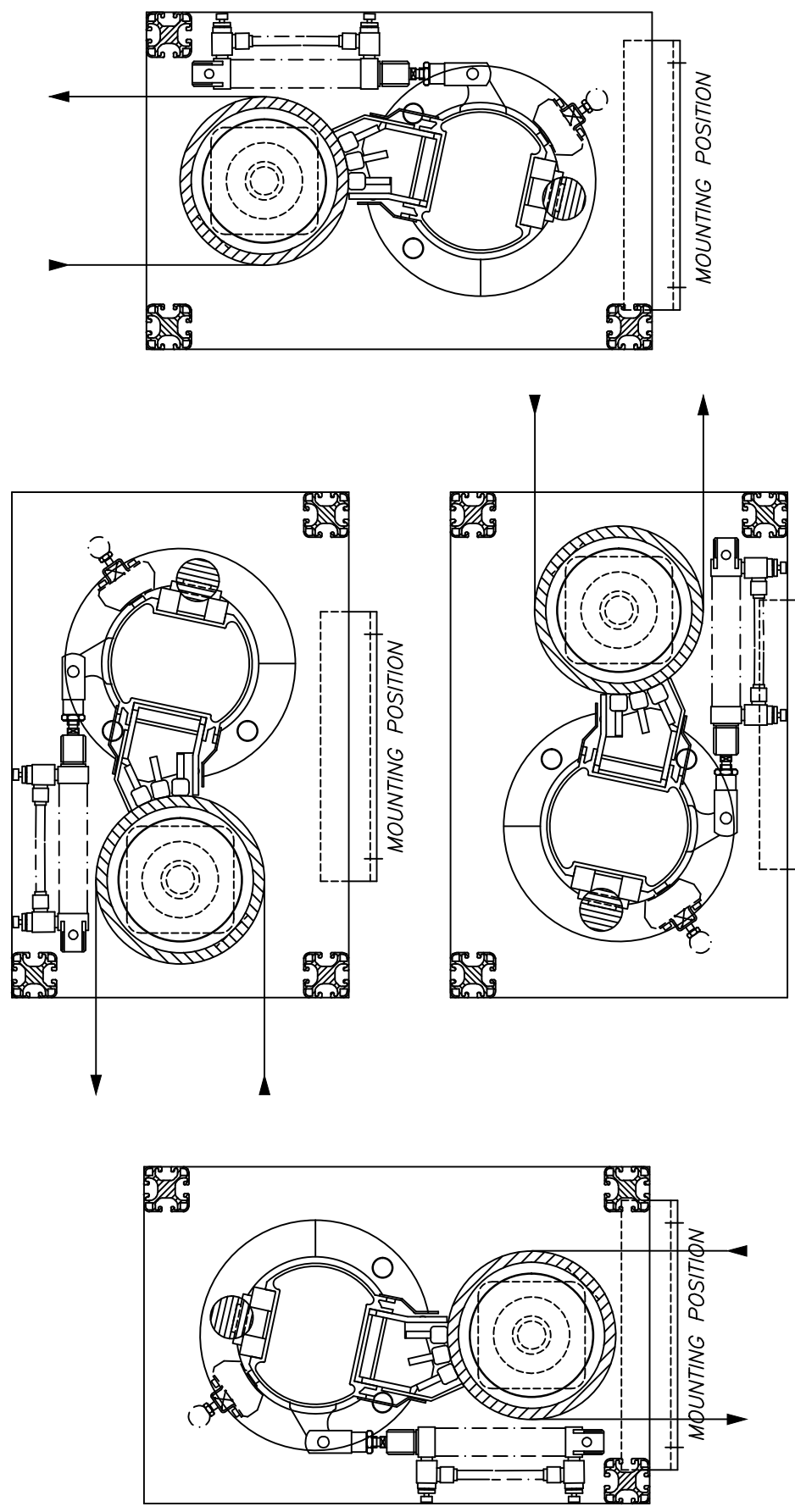

ISS. DESCRIPTION & DATE
MODIFICATIONS



Corona Supplies Ltd
THAME, OXON, OX9 3GG, ENGLAND

DRAWING NUMBER
FIG.1

TITLE
ORIENTAION DETAIL

SHT OF A4

UNLESS OTHERWISE STATED ALL DIMENSIONS ARE IN MILLIMETRES
SURFACE FINISH 1.6um
REMOVE ALL BURRS & SHARP EDGES TO 0.25 RADIUS OR CHAMFER
SCALE 1=2.5

TOLERANCES UNLESS OTHERWISE STATED DIMENSIONS
TO 0 DEC. PLACE 0.4 (.015")
TO 1 DEC. PLACE ±0.2 (.008")
2 DEC. PLACES ±0.1 (.004")
HOLE DIAS. + 0.15 - 0 (.006" -0)
ANGLES ± 1°
DIMS. APPLY AFTER PLATING

MATERIAL
XXXX XXXX
XXXXXX
FINISH
XXXXXX

APPY D DRAWN *SJM*
DATE 21-12-05
TRACED CHECKED
DATE

THE INFORMATION SHOWN ON THIS DRAWING IS CONFIDENTIAL AND MUST NOT BE COPIED REPRODUCED OR COMMUNICATED TO A THIRD PARTY WHOLLY OR IN PART WITHOUT THE WRITTEN CONSENT OF CORONA SUPPLIES LTD

1 2 3 4 5 6

ANTICLOCKWISE
ROTATION

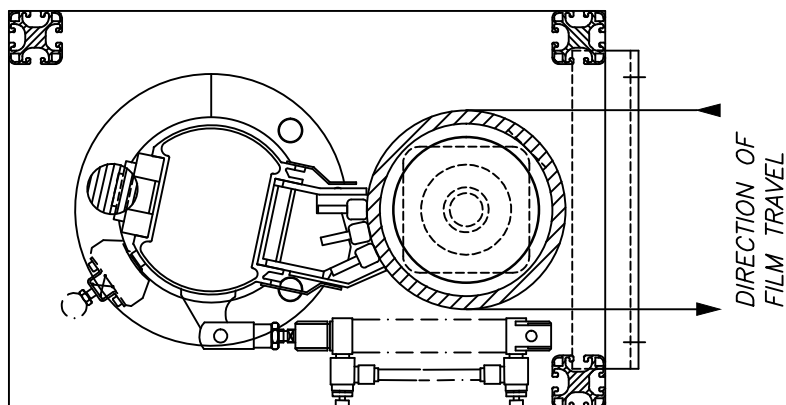

CLOCKWISE
ROTATION

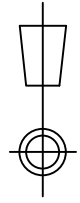
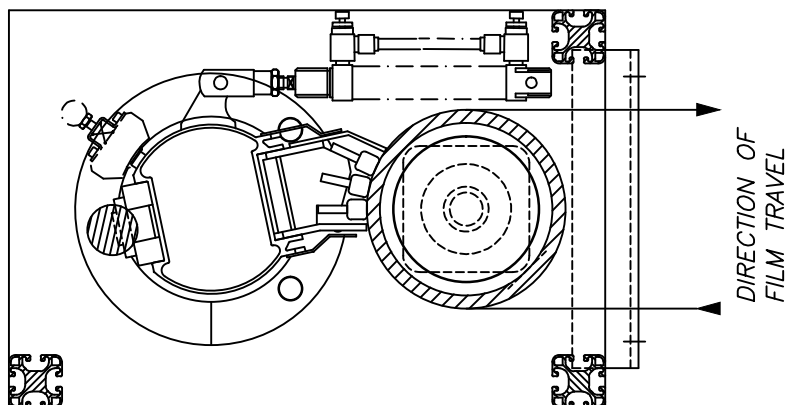

THIRD ANGLE PROJECTION
DO NOT SCALE
IF IN DOUBT ASK

ISS. DESCRIPTION & DATE
MODIFICATIONS

APPY D	DRAWN	MATERIAL	UNLESS OTHERWISE STATED ALL DIMENSIONS ARE IN MILLIMETRES	UNLESS OTHERWISE STATED DIMENSIONS	TOLERANCES UNLESS OTHERWISE STATED	UNLESS OTHERWISE STATED ALL DIMENSIONS ARE IN MILLIMETRES	Corona Supplies Ltd THAME, OXON, OX9 3GG, ENGLAND TITLE ORIENTAION DETAIL	 DRAWING NUMBER FIG.2	SHT OF A4
DATE	DATE	FINISH	TO 0 DEC. PLACE 0.4 (.015')	TO 0 DEC. PLACE 0.4 (.015')	TO 0 DEC. PLACE 0.4 (.015')				
TRACED	CHECKED	XXXXX	TO 1 DEC. PLACE ±0.2 (.008')	TO 1 DEC. PLACE ±0.2 (.008')	TO 1 DEC. PLACE ±0.2 (.008')				
DATE	DATE	XXXXX	2 DEC. PLACES ±0.1 (.004')	2 DEC. PLACES ±0.1 (.004')	2 DEC. PLACES ±0.1 (.004')				

DATE	DATE	DATE	DATE	DATE	DATE	DATE	DATE	DATE	DATE

THE INFORMATION SHOWN ON THIS DRAWING IS CONFIDENTIAL AND MUST NOT BE COPIED REPRODUCED OR COMMUNICATED TO A THIRD PARTY WHOLLY OR IN PART WITHOUT THE WRITTEN CONSENT OF CORONA SUPPLIES LTD

Handling

- Lifting the treater station onto the production line should only be carried out using mechanical means due to the weight of the unit.
- The treater should only be lifted using the lifting points located on the treater sideframes. Fig.4-5.

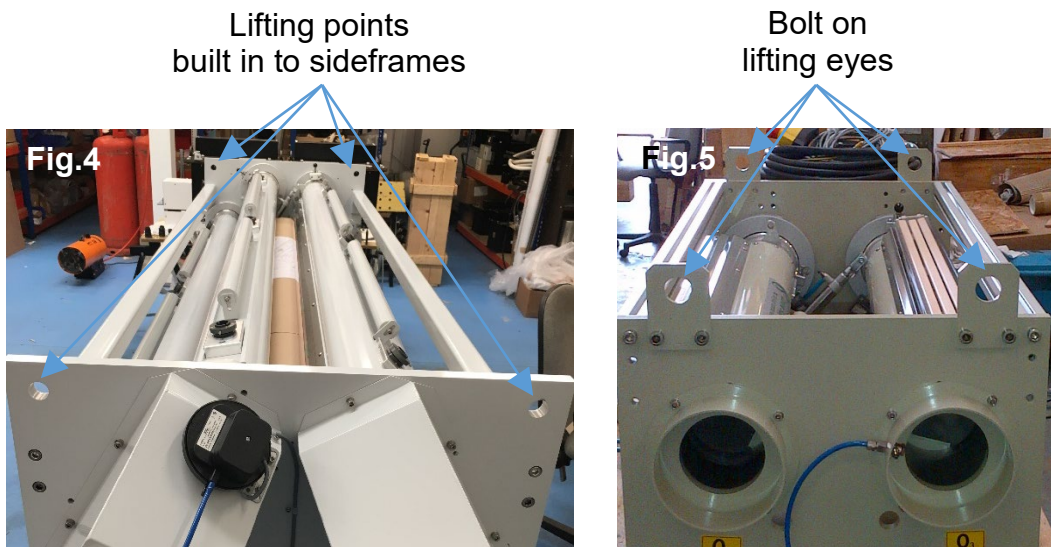

- Lifting slings / bands must confirm to – EN 1492-1 or equivalent for your country.
- Lifting shackles must confirm to – EN 13889-2003 or equivalent for your country.
- The area around the treater station when being lifted into position should be kept clear of all personnel not involved in the lifting operation.

Mounting

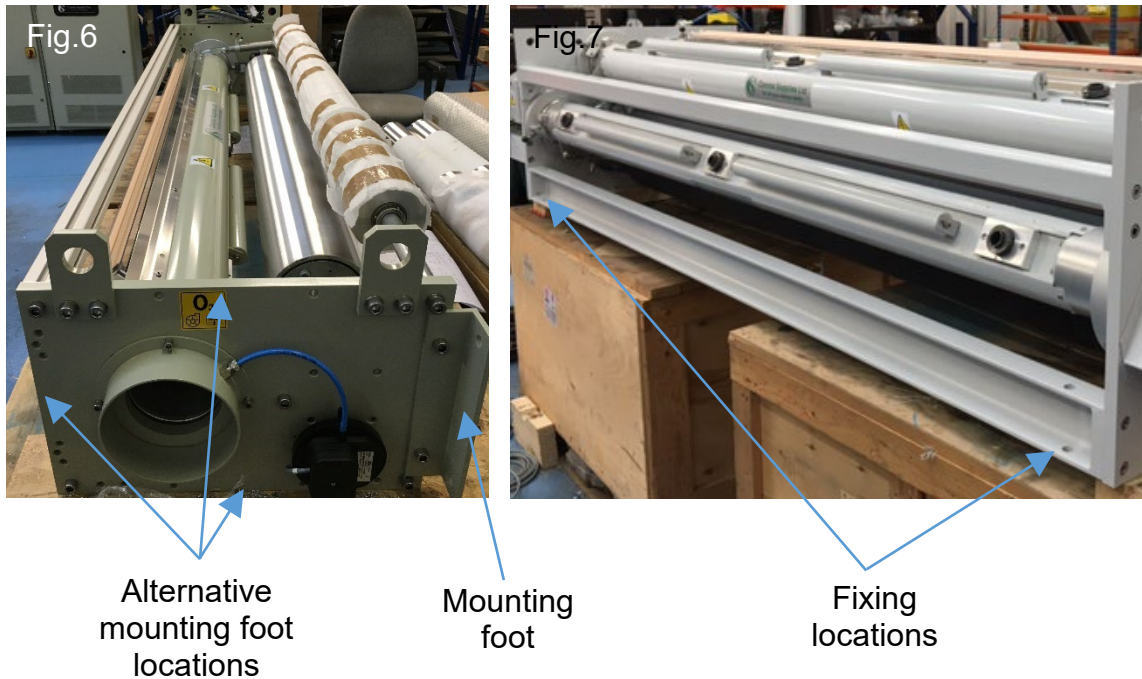

- The treater station has mounting feet located on the side of the treater to be mounted to the production line. Fig.6-7.
- Holes for mounting the treater station should be made in the production line framework in accordance with the treater station drawing in this manual.
- Depending on the size of the treater station M12 or M16 high tensile bolts should be used and secured as shown in. Fig.8.
- The treater rollers must be checked for parallelism with the production line rollers to ensure correct film path alignment. Failure to do this may cause the film “wrinkle” or move position while travelling through the treater station. Alignment should be carried out with the treater off and the production line stationary.
- Once the treater has been aligned the fixing bolts should be tightened.

1 2 3 4 5 6

TREATER FRAME

MOUNTING FOOT

BOLT

SPRING WASHER

WASHER

MACHINE FRAME

BOLT THROUGH

WASHER

NUT

3 FULL THREADS MIN

DEPTH AT LEAST
1.5 X THREAD SIZE

TAPPED
HOLE

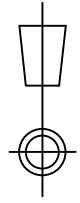

THIRD ANGLE PROJECTION
DO NOT SCALE
IF IN DOUBT ASK

ISS.	DESCRIPTION & DATE
	MODIFICATIONS

APPY D	DRAWN	MATERIAL	TOLERANCES UNLESS OTHERWISE STATED DIMENSIONS	UNLESS OTHERWISE STATED ALL DIMENSIONS ARE IN MILLIMETRES	Corona Supplies Ltd THAME, OXON, OX9 3GQ, ENGLAND TITLE MOUNTING DETAIL	 DRAWING NUMBER FIG.8	SHT OF A4
DATE	DATE	FINISH	TO 0 DEC. PLACE 0.4 (.015') TO 1 DEC. PLACE ±0.2 (.008') 2 DEC. PLACES ±0.1 (.004') HOLE DIAS. + 0.15 - 0 (.006' - 0) ANGLES ± 1° DIMS. APPLY AFTER PLATING	SURFACE FINISH 1.6µm REMOVE ALL BURRS & SHARP EDGES TO 0.25 RADIUS OR CHAMFER SCALE 1 = 1			
TRACED	CHECKED						
DATE	DATE						

THE INFORMATION SHOWN ON THIS DRAWING IS CONFIDENTIAL AND MUST NOT BE COPIED REPRODUCED OR COMMUNICATED TO A THIRD PARTY WHOLLY OR IN PART WITHOUT THE WRITTEN CONSENT OF CORONA SUPPLIES LTD

Unlocking assemblies from transit position

- When the treater station is shipped the electrode assemblies will be in the transit position to stop the electrodes coming into contact with the roller Fig.9-10. After the treater station is installed on the line but before the air supply is connected the assemblies should be put into the operating position as shown in Fig.13

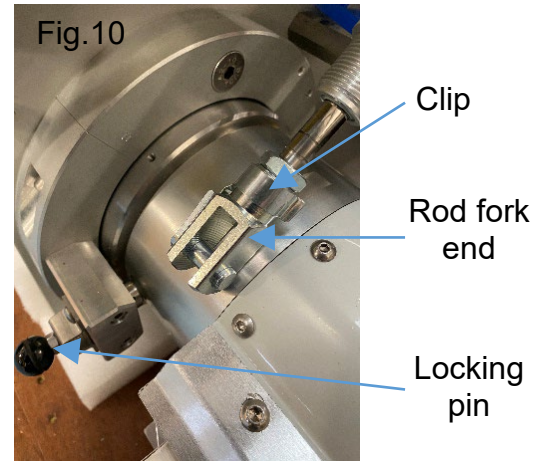
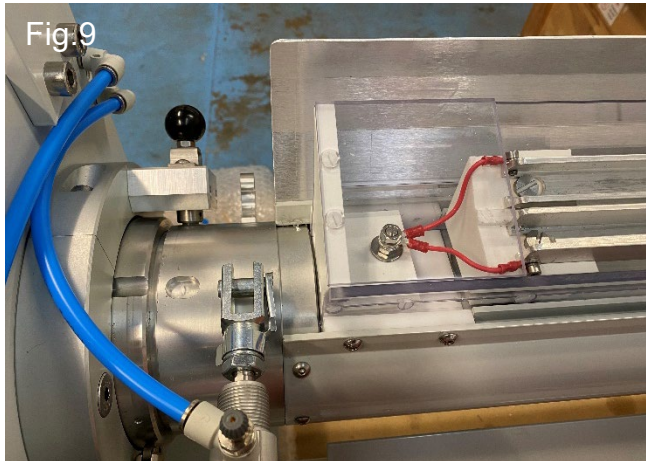

- Remove the clip from the fork end Fig.11.
- Pull out the locking pin and rotate the electrode assembly by hand until the clevis is in line with the rod fork end Fig.12.
- Push the clip through the rod fork end and the clevis then lock the clip in place Fig.13.

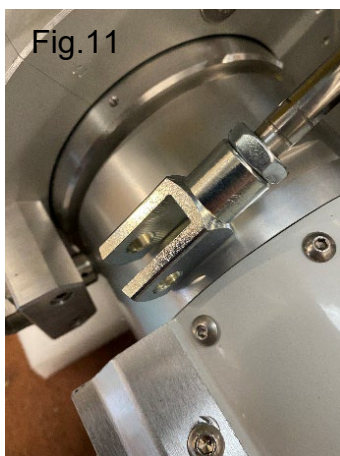

Clevis

Pneumatics

The movement of the electrode assemblies is pneumatically controlled by a manual valve and regulator which are supplied loose to allow them to be positioned in a suitable location Fig.14. The pressure in the system is set to approximately 15 Psi (1 Bar) so that the electrode assemblies can move out of the way with very little force should an obstruction on the substrate (lump or splice) in the material pass through the treater.



- The compressed air supply to the pressure regulator is made via 8mm plastic pipe and should be at a pressure of between 60 – 100 PSI (4 – 7 Bar).
- The valve and regulator should be positioned close to the treater station in a location that is easily accessible approximately 1.5m from the floor. When positioning the regulator and valve care should be taken to ensure the valve position cannot be changed accidentally.
- The pipework from the valve to the treater station must be secured to the machine framework so that it cannot become a trip or entanglement hazard.
- The pressure regulator is factory set to between 10 – 25 Psi (0.7 – 1.7 Bar) and should not be adjusted.
- In the event of any maintenance / cleaning the air supply must be isolated or disconnected.
- Electrically operated pneumatic control systems i.e. to control a Nip roll will be detailed in the circuit diagram at the end of the manual and in APP A options.

Electrical

Electrical circuits & connections are detailed in the circuit diagram “Circuit diagram treater installation” found at the back of this manual.

- Control circuits on the treater station where possible are 24vDC. These include the interlock and speed sensor circuits.
- Supply circuits to the generator, treater station and aux electrical equipment i.e. Ozone extraction fan will be either 1 phase or 3 Phase AC and will be identified by one or more of the following labels.



- Cables from the generator to the treater station should be attached to the production line framework or run in cable trays so that they cannot become a trip or entanglement hazard and are out of operators reach.
- The treater station must be earthed which is made via the high voltage transformer however a secondary safety earth must be connected from the treater station frame to the production line framework Fig.15-16.

Earth cable to connect to high voltage transformer case

Earth cable to connect to production line framework

Earth cable to connect to high voltage transformer case (remote)

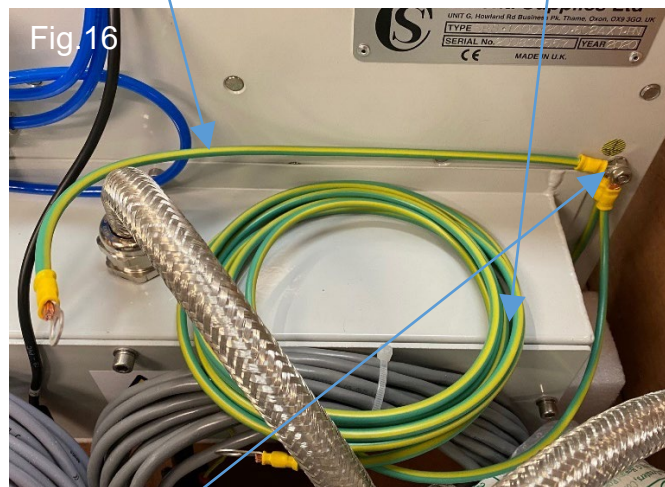

Earth stud

High Voltage transformer

A high voltage transformer (HV) is used to boost the voltage from the generator to a level capable of striking an arc across the air gap between the electrodes and the roller. This voltage varies depending on many factors including air gap, dielectric properties of the material and humidity but is in the region of 5,000 to 10,000 volts.

The HV transformer is usually mounted on the treader framework and its output connection enclosed within a cover Fig.17. **DANGER!!! Terminal covers must not be removed unless the generator has been switched off and isolated from the main supply.**

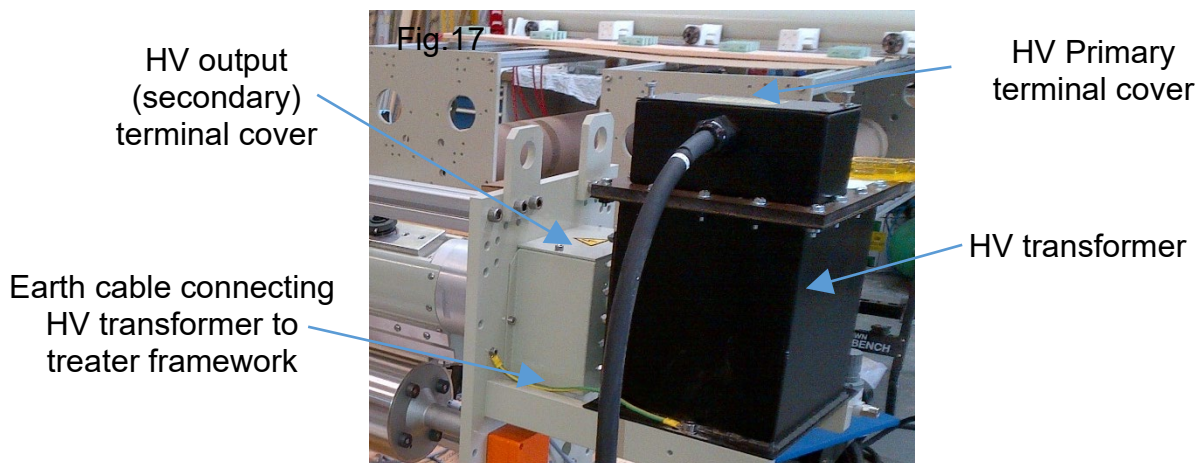

The HV transformer may also be mounted remotely if space for the treader station is at a premium for example. The transformer will be connected to the treader station via a remote HV cable which is a high voltage screened cable which is earthed at both ends either with a flying lead or through EMC type cable glands.



The remote HV transformer must be mounted in the upright position and secured to the production line framework using the fixing holes in the base Fig.18.

Ozone Extraction

CAUTION!!! The ozone produce by the corona treatment process is highly toxic and must be removed from the treater station and exhausted to atmosphere outside the work area. It must not be possible for the ozone to be introduced back into the work area through open windows, vents or air conditioning systems.



- Ensure the ozone port(s) (as indicated by the above label) are connected to the input port of the ozone extraction fan with suitable corrosion and heat resistant (>80 °C) ducting. If the treater has multiple ozone ports a suitable adaptor will be provided to combine these into one port allowing connection to a single piece of ducting or directly to the extraction fan. To simplify installation a short run of flexible ducting can be run from the treater ports to the adaptor or extraction fan.
- Depending on the size of the treater station (treat width & number of electrodes) a suitable fan will be offered with the following port sizes.

Fan flow rate (m ³ /min)	Fan pressure (mm water)	Port diameter (mm)
7	4	100
	6	100
14	4	100
	6	150
28	6	150
	10	200
50	10	250

- The output of the extraction fan should be connected to suitable rigid ducting made from corrosion resistant materials and ducted to atmosphere outside the work area. For a ducting run of up to 5m with 2-3 wide bends ducting of the same diameter of the extraction fan ports can be used. For longer length ducting runs a larger diameter ducting must be used. Fig.19-20.
- The extraction system should be installed in such a way that water is prevented from entering the system and returning to the ozone extraction fan.
- The extraction and exhaust system should be installed in accordance with local legislation

Fig. 19

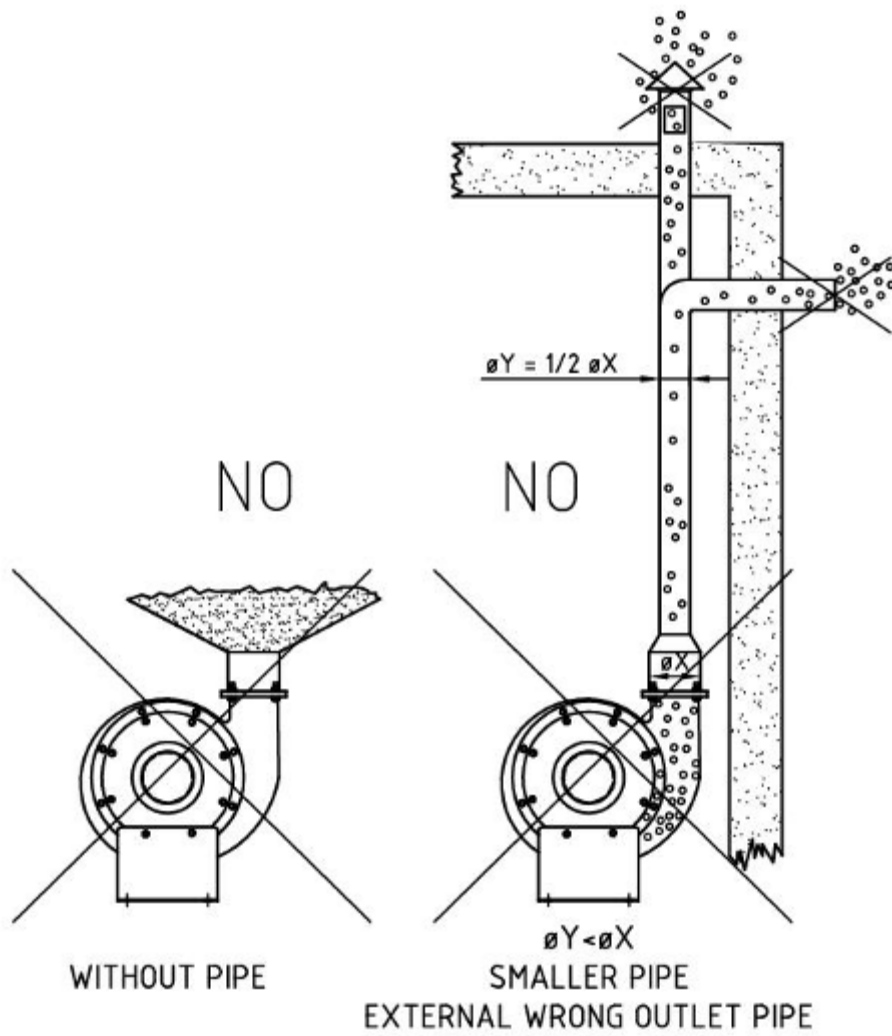
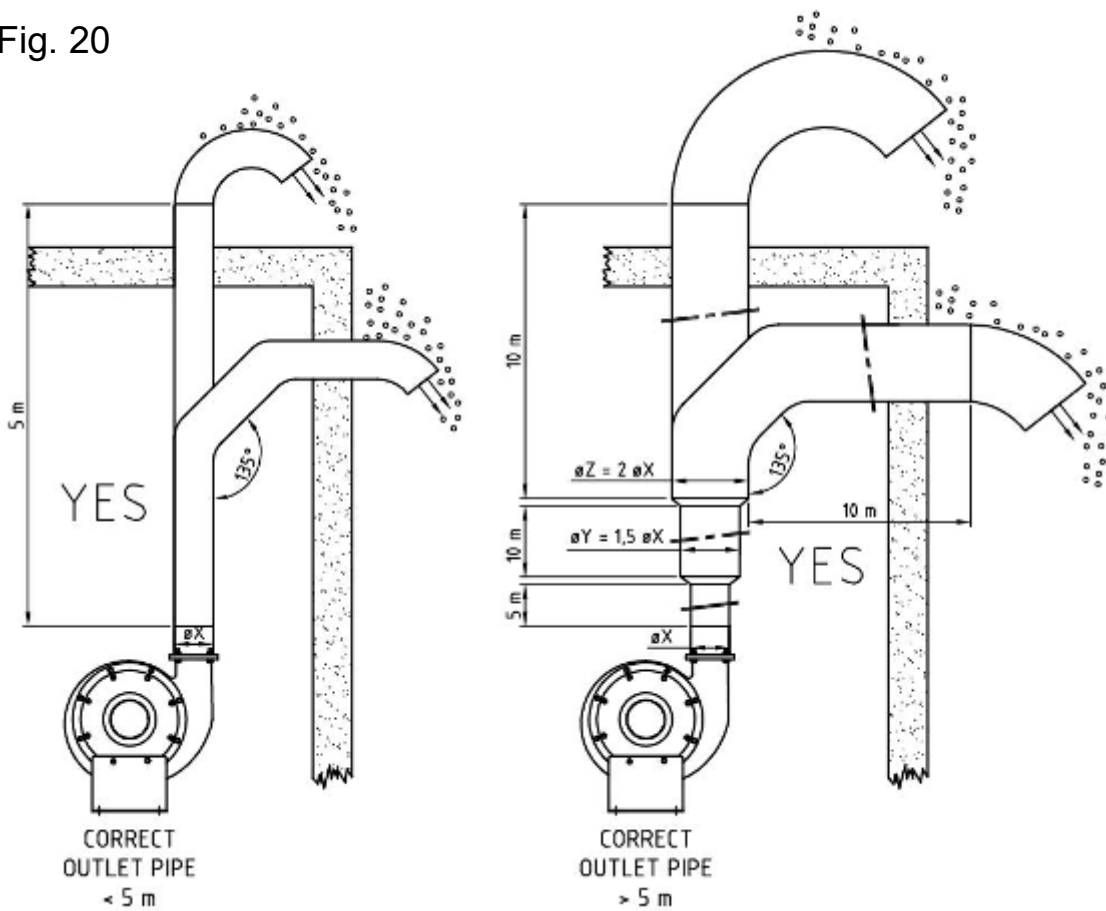

Fig. 20



Commisioning

Air-gap setting

CAUTION!!! Before adjusting the distance between the electrodes and the discharge roller, switch off the generator and disconnect from the main supply. Allow the electrodes to cool for a minimum of 10 minutes.

The gap between the electrodes and the roller is an important part of the corona treating process. The air gap must be large enough for the material to pass through without coming into contact with the electrodes but not so large that the corona discharge becomes uneven. Corona Supplies assembly type treaters come with precision air gap adjusters located evenly along the complete length of the electrode allowing for precise and even gap setting Fig.21.

Prior to delivery, the treater system is fully tested and the air gap set to 2 – 2.5mm which is the optimal gap for metal electrodes on an silicon covered roller.

However, the distance between the electrodes and the roller (air gap) should be checked before first use once the treater station has been mounted on the customers machine and at regular intervals (see maintenance guide). For optimal performance, the air gap should be approximately 2 – 2.5mm.

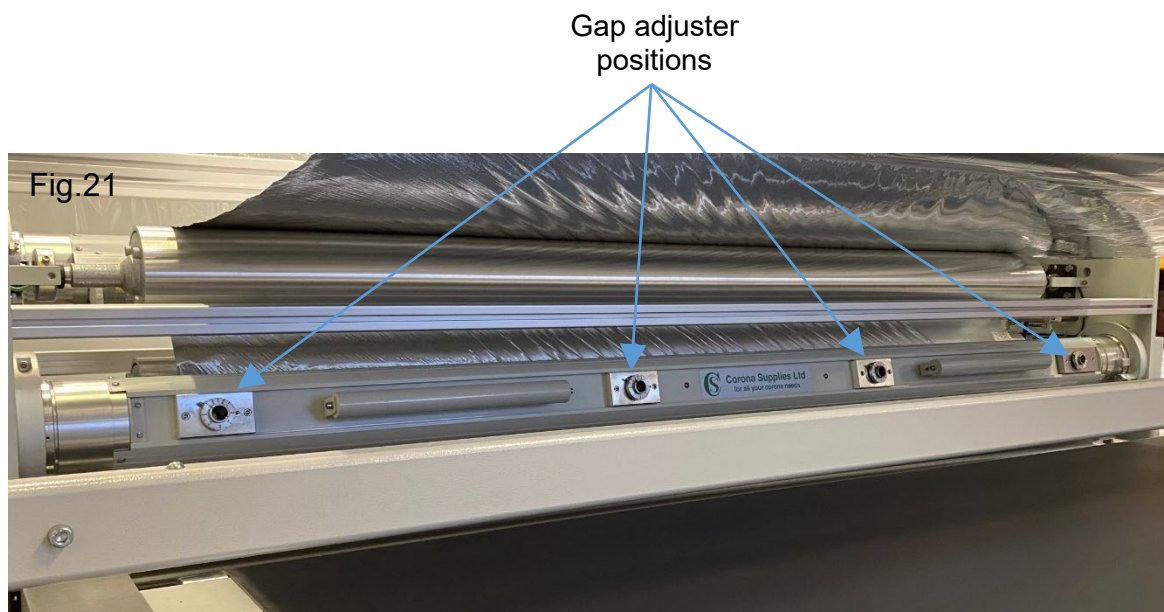

Air gap adjustment after machine installation (installation of a replacement electrode or electrode cartridge).

- Ensure the electrode assembly is in the operating position.
- Loosen off the two grub screws (1/2 turn) in the adjuster block Fig.22-23.

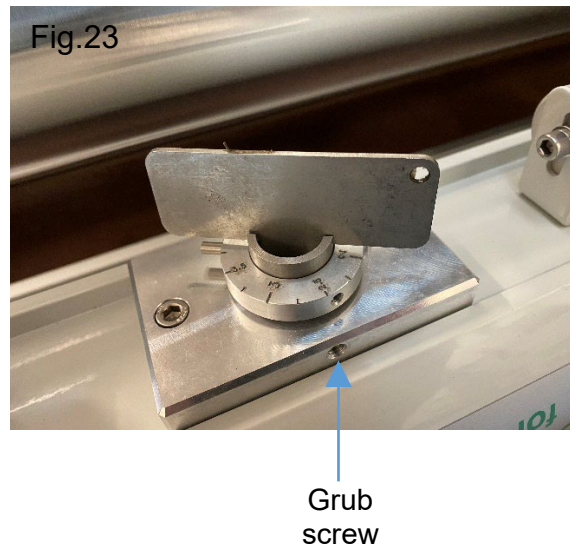
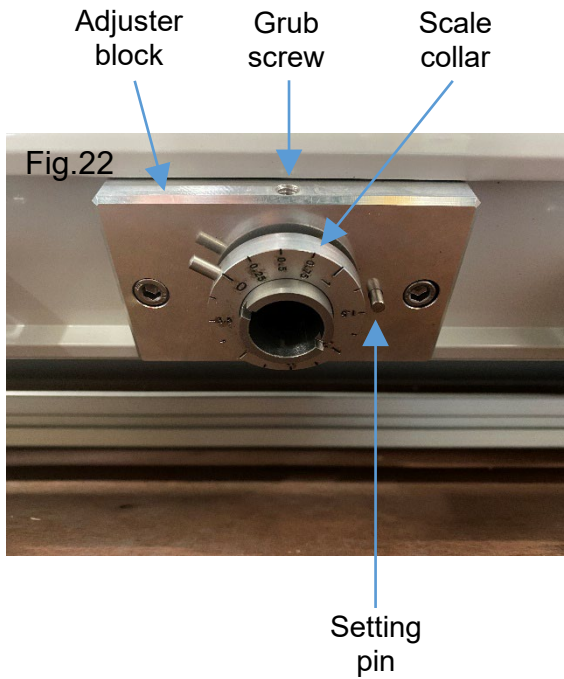

- Insert a piece of material 2 – 2.5mm thick between the electrode and the roller on the incoming side of the electrode cartridge at the centre of the machine Fig.24. Rotate the gap adjuster **Anti-clockwise** to move the electrode further away from or **Clockwise** to move the electrode closer to the roller Fig.25.

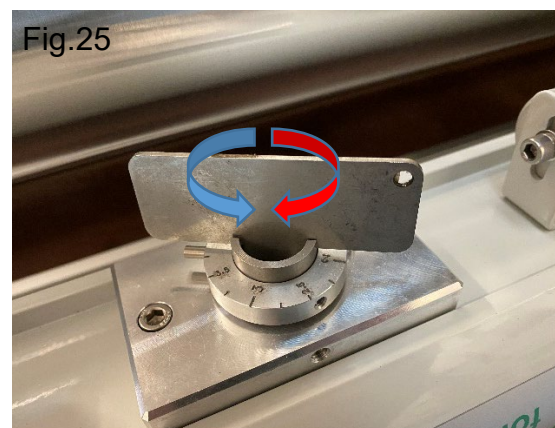
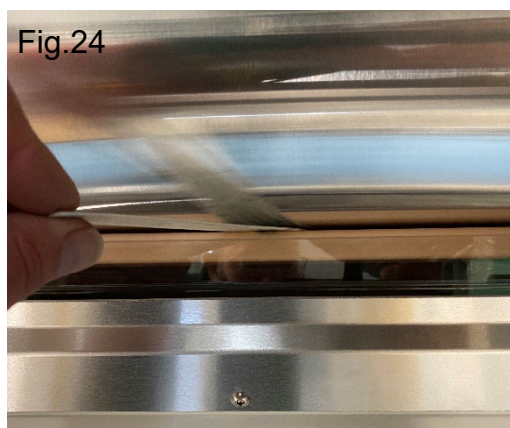

- Once the incoming side of the electrode cartridge is set, the 2 – 2.5mm material should be moved to the outgoing side of the cartridge to check the gap is the same. If the gap differs the tilt adjuster will need to be adjusted to achieve the correct gap. Loosen the locking nut and turn the hex screw (**Anti-clockwise**) to increase the gap or (**Clockwise**) to decrease the gap on the outgoing side of the assembly Fig.26-27. Tighten the locking nut once set.

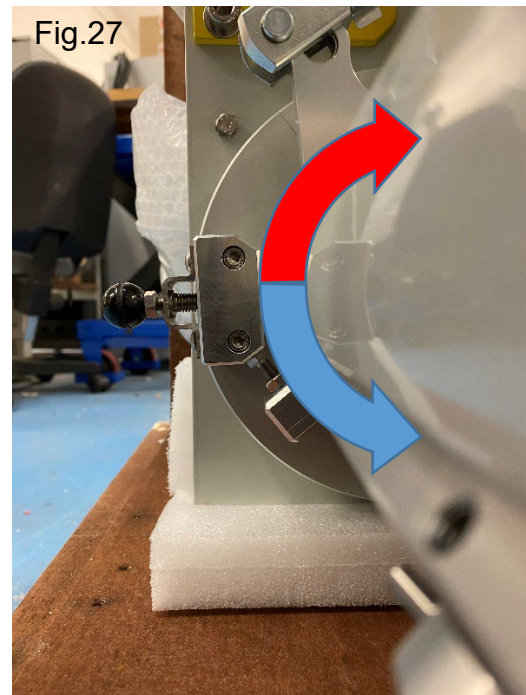
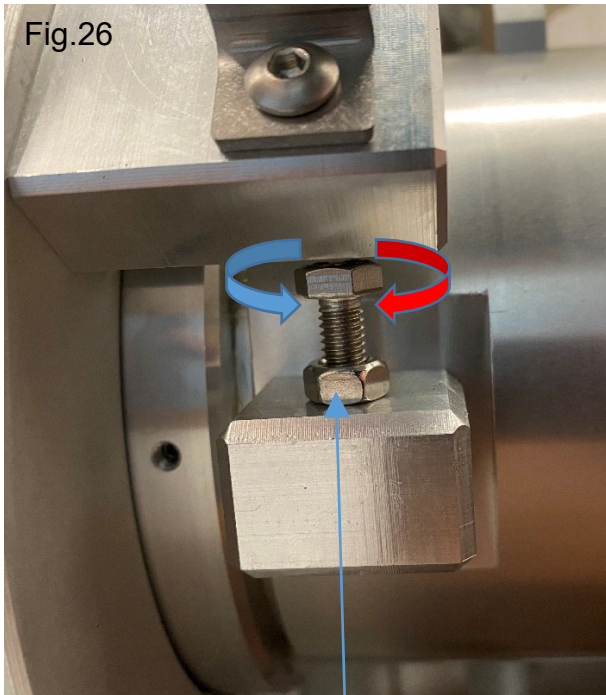

Locking nut

- Once the airgap on incoming and outgoing side of the electrode cartridge is set correctly in the middle of the assembly the process should be repeated along the length of the assembly to ensure the airgap is even along the complete width of the treater Fig.28. Note the tilt should not require any further adjustment.



- Once the gap is even along the entire length and on both sides of the assembly retighten the two grub screws (finger tight) in the adjuster blocks Fig.22-23.
- If any of the gap adjusters have been adjusted the scale collars should be realigned so that the distance of the gap is adjacent to the setting pin. Fig.29. Loosen off the grub in the locking collar and rotate the collar until the set gap (2 – 2.5mm) is adjacent to the setting pin and retighten the grub screw. Fig 30.

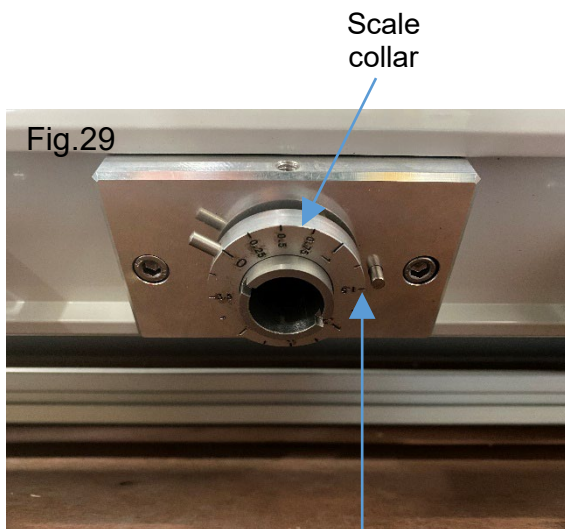

Fig.29

Scale collar

Set gap adjacent to Setting

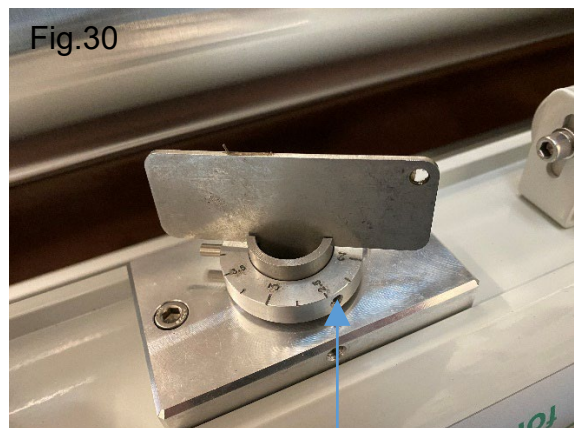

Fig.30

Grub screw

Electrical Interlocks

During Commissioning the treater station interlocks must be checked for correct operation before the system is put into production. The interlocks can be checked by testing the continuity of the interlock circuit using a multimeter (see circuit diagram) or by connecting the treater station to the generator and monitoring the interlock LED on the front panel. To test the interlock circuit, ensure the following is met.

- Electrode assemblies closed (operating position)
- Ozone extraction fan running
- E-stop button disengaged
- Nip roller in operating position (option)
- Access covers / doors closed (option)
- Pressurisation fan running (option EX areas only)

The interlock circuit should now be closed with continuity in the circuit or the interlock LED on the generator lit.

- The assembly position switches should be checked by opening the electrode assemblies using the pneumatic valve and checking that the interlock circuit opens. The circuit should open almost immediately the assemblies start to move.
- The Air flow switch should be checked by switching the ozone extraction fan off. The interlock circuit should open within 30 seconds of the fan being switched off.
- The E-stop button should be depressed to ensure the interlock circuit opens immediately.
- The Nip roller (option) position switches should be checked by opening the nip roller by actuating the pneumatic valve. The interlock circuit should open immediately
- Access cover / door switches (option) should be checked by opening covers / doors one by one. The interlock circuit should open immediately.
- The pressurisation switch should be checked by switching off the pressurisation fan (option). The interlock circuit should open within 30 seconds of the fan being switched off.

DANGER!!! If any of the above fail to operate correctly the machine should not be put into production and Corona Supplies service dept should be contacted for advice.

Start-up

Once commissioning is complete the treater station can be put into production.

Webbing up

CAUTION!!! Before webbing up the treater station ensure the generator is switched off. Allow the electrodes to cool for a minimum of 10 minutes.

- Open the electrode assemblies using the pneumatic valve.
- Pass the material over the roller ensuring it is travelling in the correct direction as shown in the treater station drawing.
- Ensure the web is under tension before closing the electrode assemblies using the pneumatic valve.

Now refer to the generator manual to continue startup of the corona treater system

Maintenance

To ensure the trouble free operation of your corona treater some regular maintenance is required. This will extend component life and lead to less down time.

! Warning !



The voltages inside the corona treater can exceed 10,000 volts; the generator must therefore be switched off & isolated from the mains supply before any work is carried out on the corona treater or generator.



Metal electrodes reach temperatures in excess of 150 °C during operation. Any work inside the corona treater station should only be carried out after the electrodes have had time to cool. The corona must be stopped and the extraction fan left running for approximately 10 minutes before the electrode extrusions are opened and any covers removed.

If in any doubt contact Corona Supplies service department for assistance

Corona Supplies Ltd
UNIT G
Howland Road Business Park
Thame
OX9 3GQ

T: +44 (0) 1844 261779
F: +44 (0) 1844 358187
E: service@coronasupplies.co.uk
W: www.coronasupplies.co.uk

ELECTRODES / ELECTRODE CARTRIDGES

The electrodes should be cleaned regularly to maintain system efficiency and to achieve maximum operational life. The following maintenance schedule is recommended.

MONTHLY	6 MONTHLY
<p>Open electrode assemblies and lock into transit position.</p> <p>Using an airline or stiff brush remove any build-up of dust and debris from around the electrodes and Perspex screens.</p> <p>Inspect for signs of arcing around the PTFE mounting blocks, electrode support flags, Perspex screens & HT connections. Arcing should be removed using emery/sand paper.</p> <p>Inspect for signs of moisture build up inside the cartridge. Moisture should be removed using a cloth & light solvent.</p> <p>Ensure all components are dry and secured correctly before putting the machine back into operation</p> <p style="text-align: center;">SEE DRAWING 001-0017-9 FOR ELECTRODE CARTRIDGE DETAILS & PART DESCRIPTIONS.</p>	<p>Open electrode assemblies and lock into transit position.</p> <p>Remove electrode cartridges from extrusions as described on pages 25-26.</p> <p>Disassemble electrode cartridges and thoroughly clean (see quarterly).</p> <p>Ensure all components are dry and secured correctly before replacing cartridges back into the extrusions.</p> <p>Check air gap between electrodes and base roll and adjust as required to achieve a gap of approximately 2 – 2.5mm. Ensure the gap is even along each electrode. The tilt screw may need to be adjusted to ensure the gap is the same on the incoming & outgoing sides of the electrode cartridge.</p>

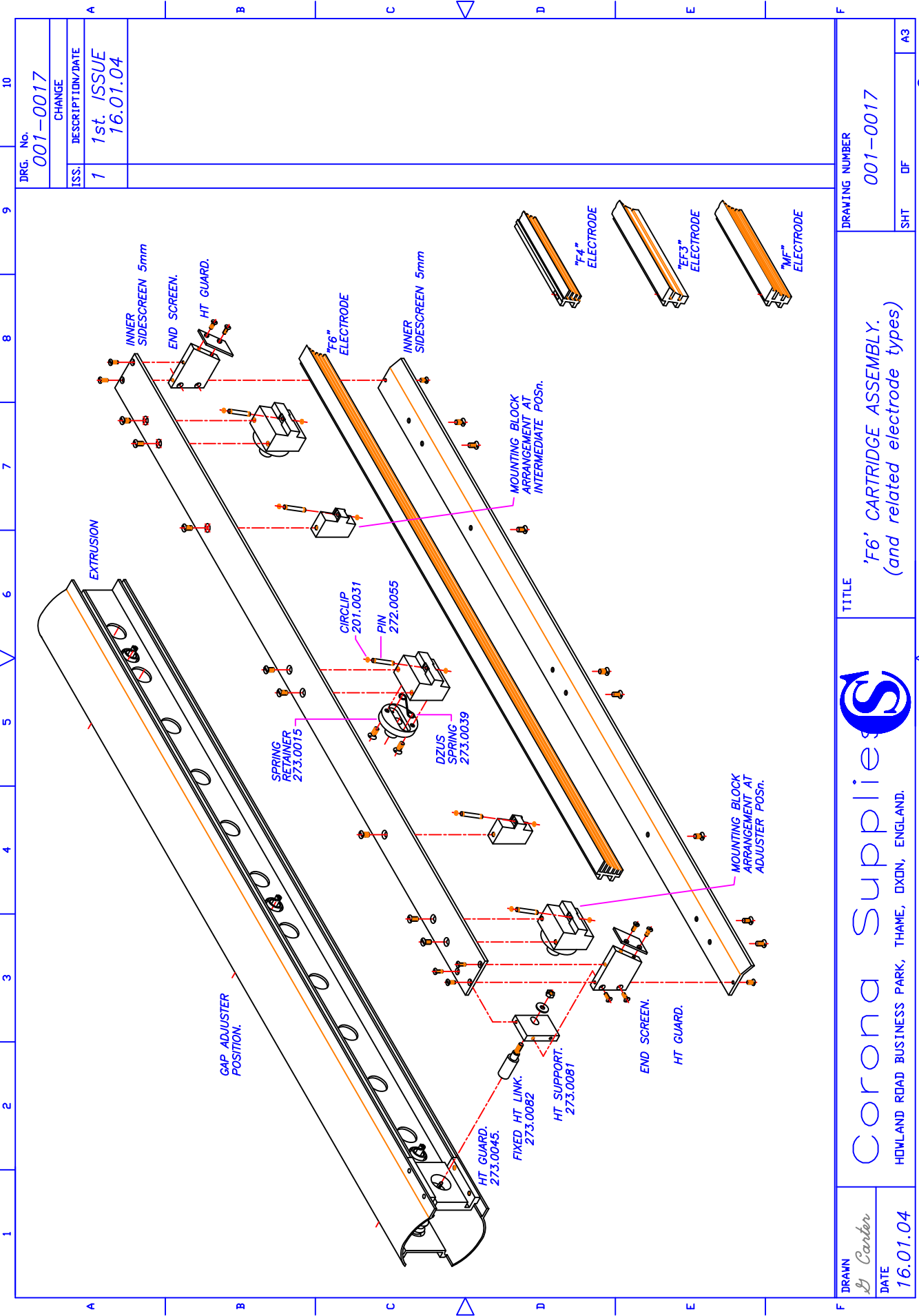

DRG. No. 001-0017
CHANGE

ISS. 1
DESCRIPTION/DATE
1st. ISSUE
16.01.04

DRAWING NUMBER
001-0017

TITLE
'F6' CARTRIDGE ASSEMBLY.
(and related electrode types)

Corona Supplies
HOWLAND ROAD BUSINESS PARK, THAME, OXON, ENGLAND.

DRAWN
B. Carter
DATE
16.01.04

THE INFORMATION SHOWN ON THIS DRAWING IS CONFIDENTIAL AND MUST NOT BE COPIED REPRODUCED OR COMMUNICATED TO A THIRD PARTY WHOLLY OR IN PART WITHOUT THE WRITTEN CONSENT OF CORONA SUPPLIES

SHT DF A3

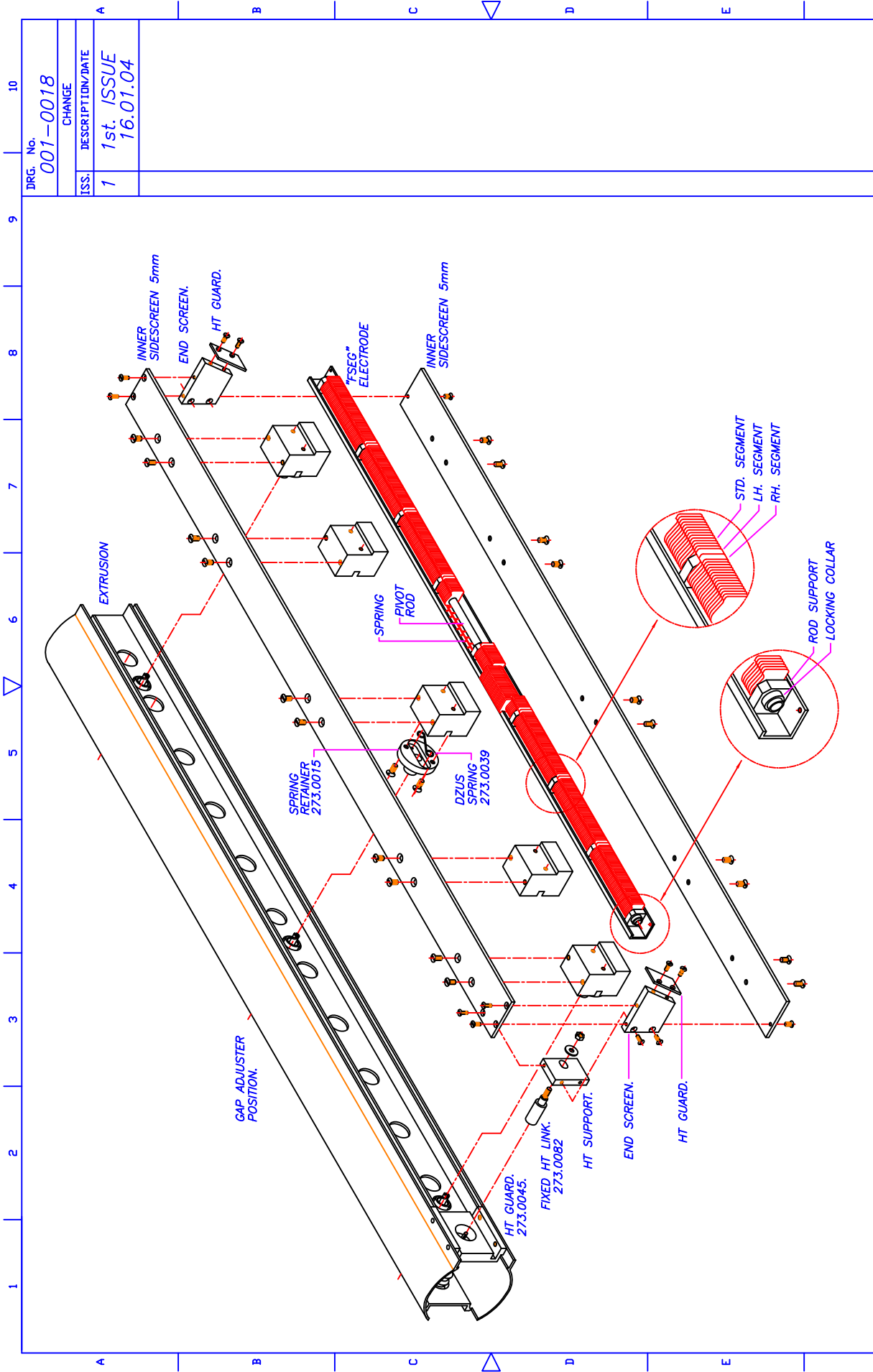

DRG. No. 001-0018
CHANGE

ISS. 1
DESCRIPTION/DATE
1st. ISSUE
16.01.04

DRAWING NUMBER
001-0018

SHT DF A3

TITLE
'FSEG' CARTRIDGE ASSEMBLY.

Corona Supplies
HOWLAND ROAD BUSINESS PARK, THAME, OXON, ENGLAND.

DRAWN
B. Carter
DATE
16.01.04

THE INFORMATION SHOWN ON THIS DRAWING IS CONFIDENTIAL AND MUST NOT BE COPIED REPRODUCED OR COMMUNICATED TO A THIRD PARTY WHOLLY OR IN PART WITHOUT THE WRITTEN CONSENT OF CORONA SUPPLIES ©20.

DRG. No.	001-0019
CHANGE	
ISS.	DESCRIPTION/DATE
1	1st. ISSUE 16.01.04

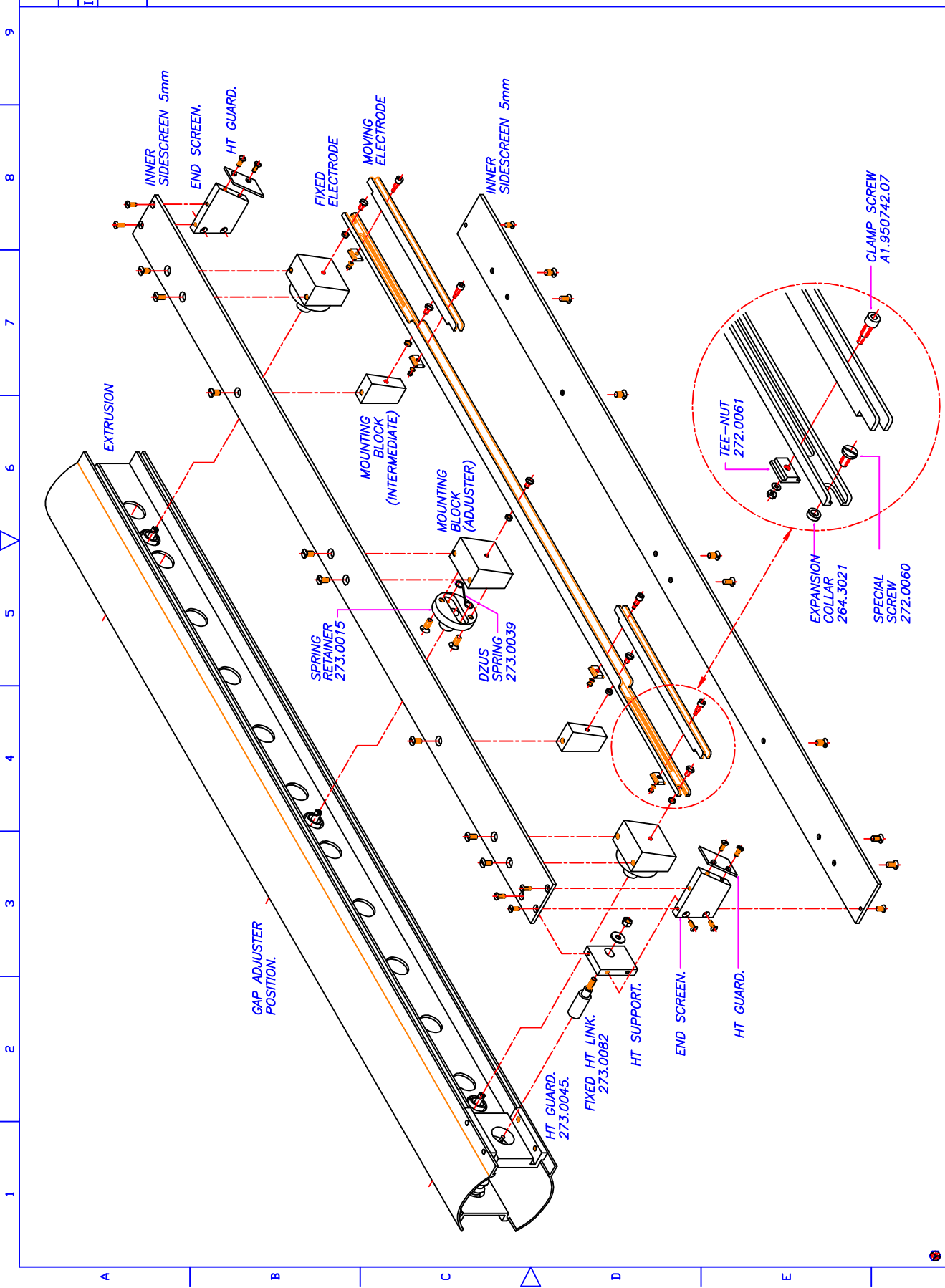

DRAWING NUMBER	001-0019
SHT	DF
A3	

TITLE
'Ua' CARTRIDGE ASSEMBLY.

Corona Supplies
 HOWLAND ROAD BUSINESS PARK, THAME, OXON, ENGLAND.

DRAWN	<i>L Carter</i>
DATE	16.01.04

THE INFORMATION SHOWN ON THIS DRAWING IS CONFIDENTIAL AND MUST NOT BE COPIED, REPRODUCED OR COMMUNICATED TO A THIRD PARTY WHOLLY OR IN PART WITHOUT THE WRITTEN CONSENT OF CORONA SUPPLIES ©20.

REMOVAL OF THE ELECTRODE CARTRIDGE.

To remove the electrode cartridge from the extrusion follow the steps below.

- Remove the clip securing the pneumatic cylinder rod fork end to the clevis on the assembly hub and rotate the extrusion until access can be gained to the gap adjusters. Fig.1



- Insert a large flat bladed screwdriver into each gap adjuster and rotate **Anti-clockwise** a quarter of a turn to unlock the cartridge Fig.2-3. To lock the cartridge turn **Clockwise**.
CAUTION!!! Care should be taken to ensure the electrode cartridge cannot fall out of the extrusion when the last adjuster is unlocked.

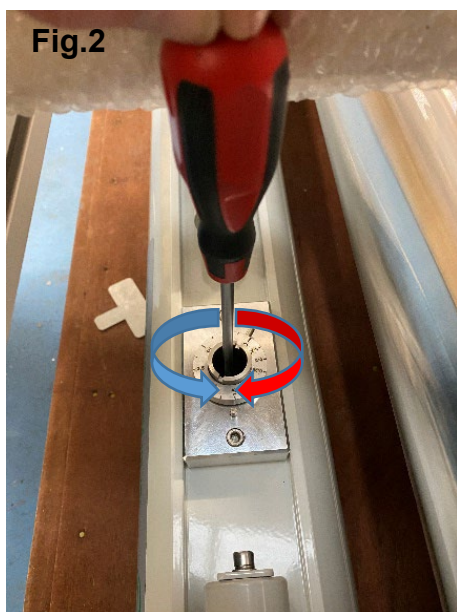

- Remove the electrode cartridge by holding both ends (for longer units two persons may be required) and gently pulling it away from the extrusion. Fig.4.



- When replacing the electrode cartridge follow the above steps but in reverse taking care to align the HT connection before pushing the electrode cartridge home.

EXTRUSIONS / PNEUMATICS

6 MONTHLY

Ensure electrode extrusions are free to open & close. Adjust pressure regulator so that the extrusions will open slightly should a “lump” go through the corona treater. Recommended pressure approximately 1 Bar. See page 12 of this manual

Ensure the gap adjusters are free to move. Lubricate with grease if required.

Ensure the HT connections located inside the extrusion are clean and not damaged. A light solvent can be used to clean the ceramic insulator if required. Ceramic Insulators that are cracked should be replaced.

Ensure Interlock switches operate correctly and are securely fastened to the bearing housing. The interlock switch should operate almost immediately as the extrusion starts to rotate.

Ensure counter balance weights are securely fastened to the extrusions.

SEE DRAWING 001-0010 to 001-0015 FOR DETAILS & PART DESCRIPTIONS.

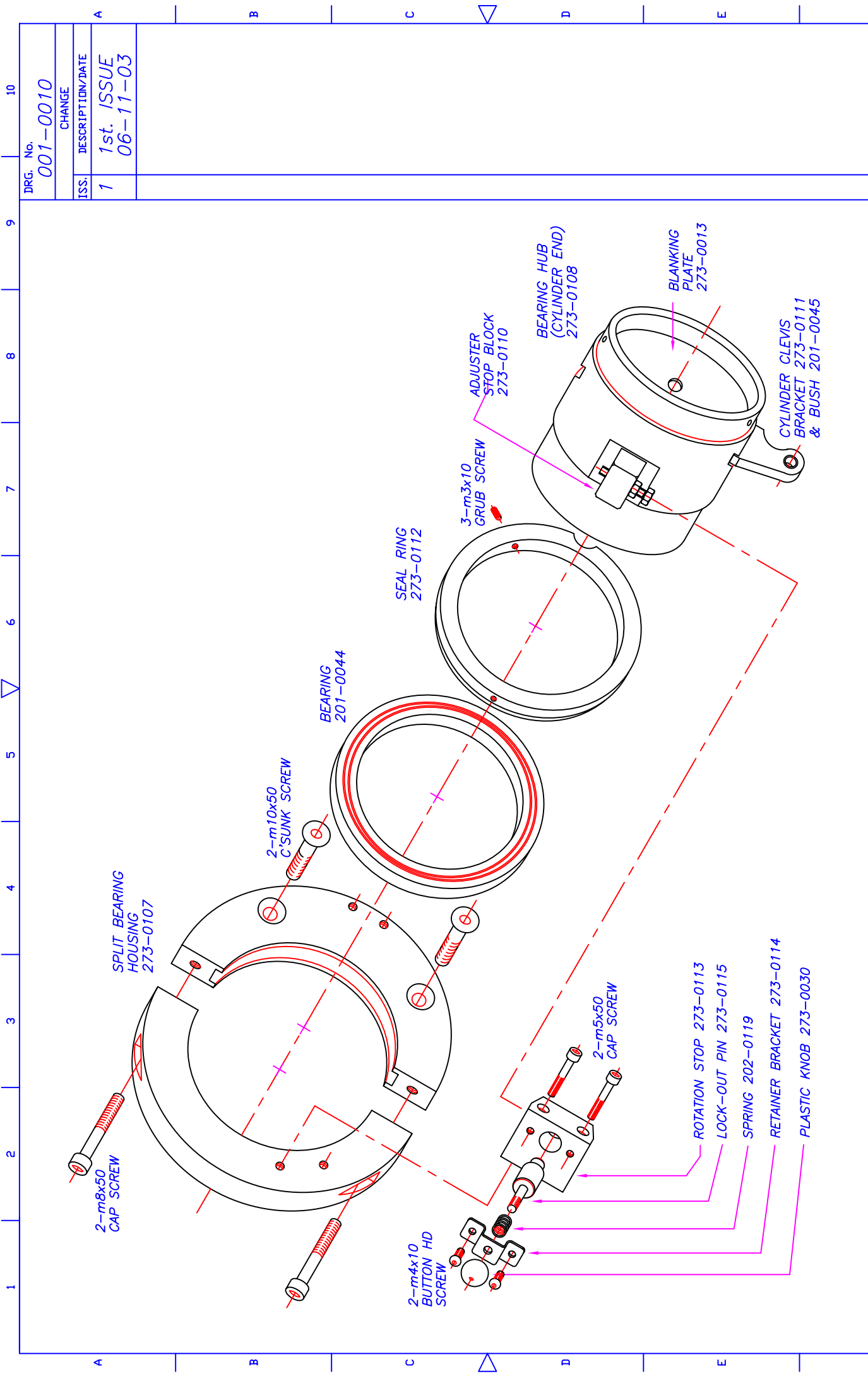

DRG. No.	001-0010
CHANGE	
ISS.	DESCRIPTION/DATE
1	1st. ISSUE 06-11-03

DRAWING NUMBER	001-0010
SHT	DF
OF	A3

TITLE
L.P.E. HUB ASSEMBLY
(PNEUMATICS END)



Corona supplies
HOWLAND ROAD BUSINESS PARK, THAME, OXON, ENGLAND.

DRAWN	<i>A Carter</i>
DATE	06-11-03

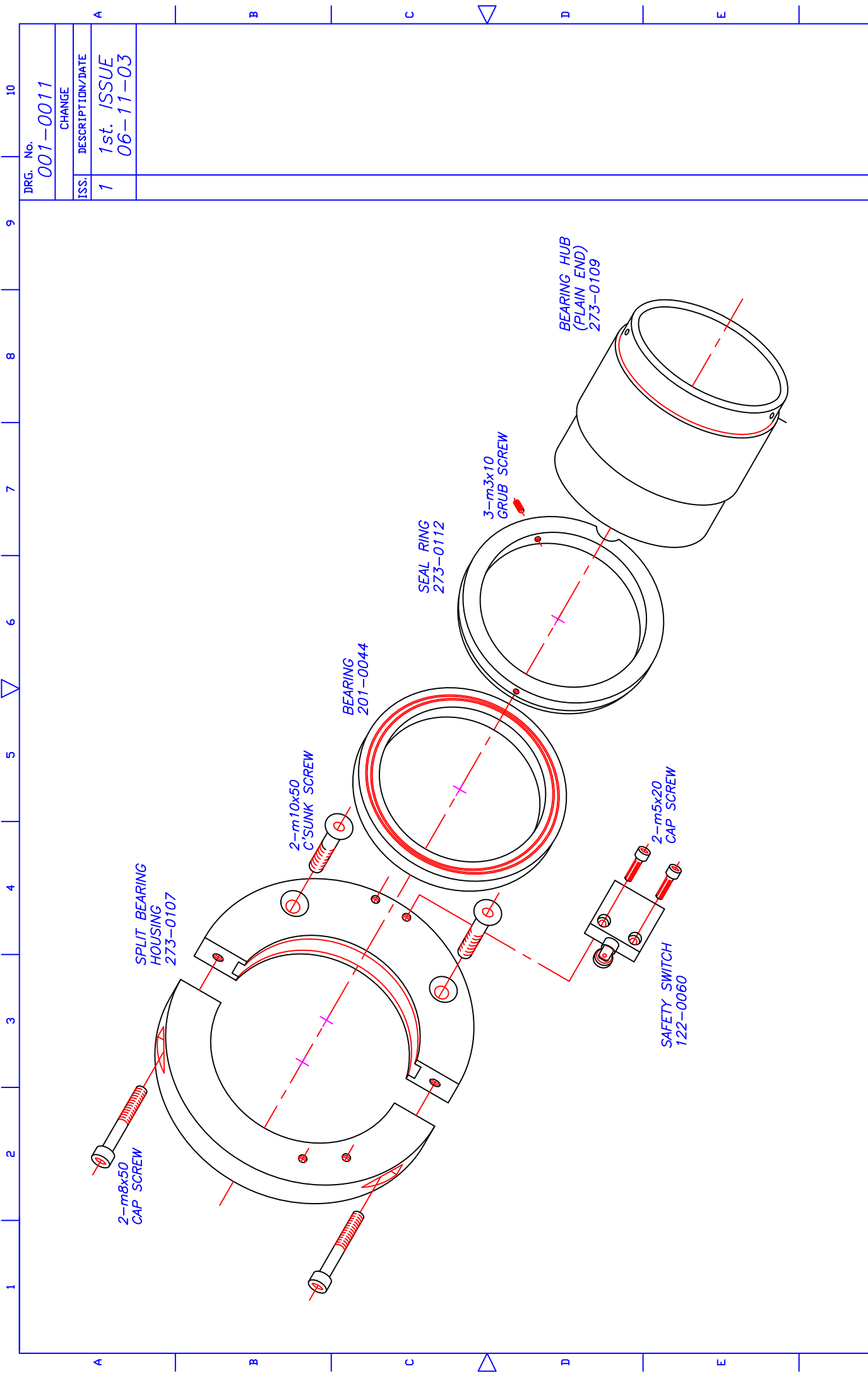

DRG. No.	001-0011
CHANGE	
ISS.	DESCRIPTION/DATE
1	1st. ISSUE 06-11-03

DRAWING NUMBER	001-0011
SHT	DF
DF	A3

TITLE
**L.P.E. HUB ASSEMBLY
(OZONE END)**

Corona Supplies
HOWLAND ROAD BUSINESS PARK, THAME, OXON, ENGLAND.

DRAWN	<i>A. Carter</i>
DATE	06-11-03

THE INFORMATION SHOWN ON THIS DRAWING IS CONFIDENTIAL AND MUST NOT BE COPIED REPRODUCED OR COMMUNICATED TO A THIRD PARTY WHOLLY OR IN PART WITHOUT THE WRITTEN CONSENT OF CORONA SUPPLIES ©20.

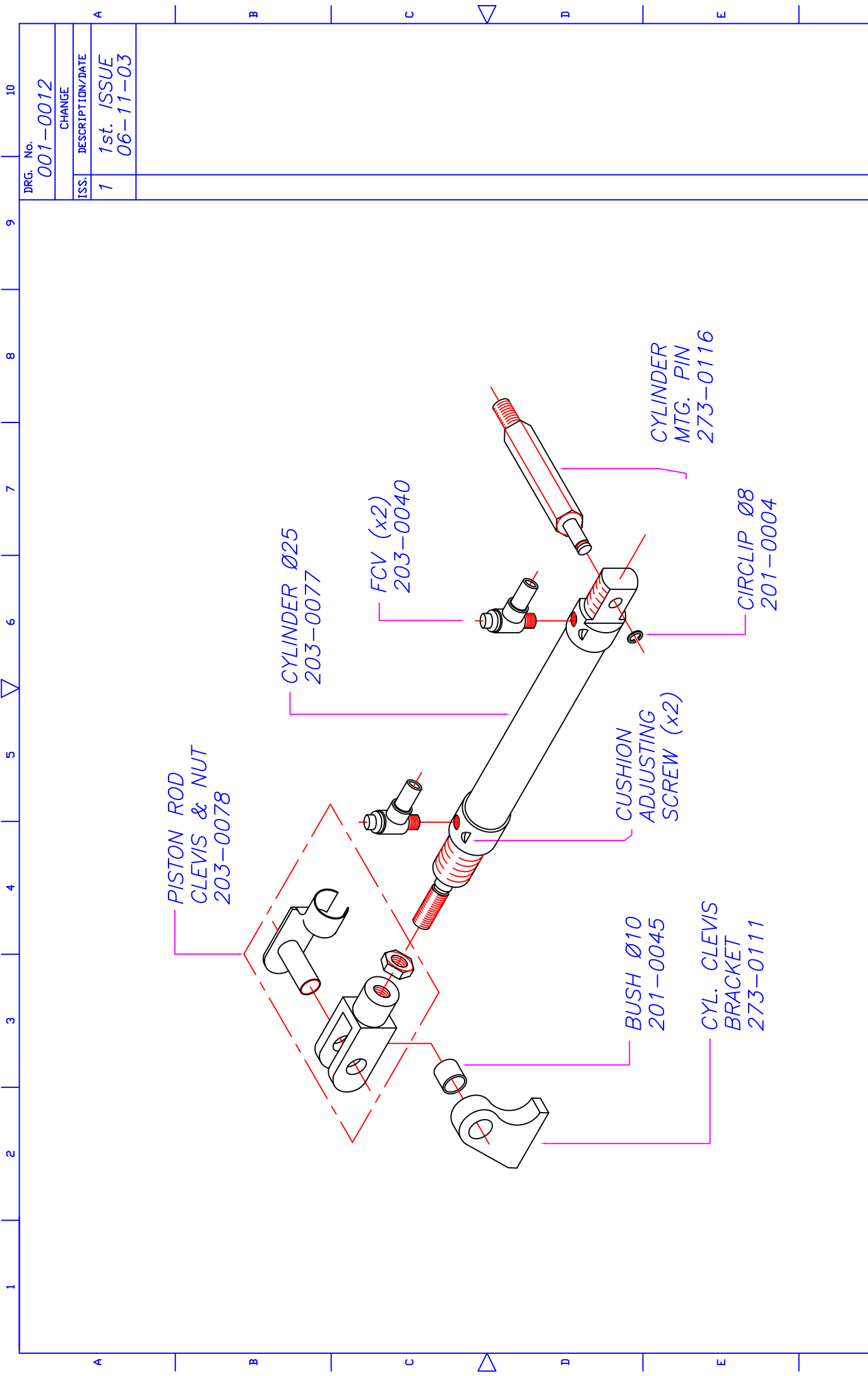

DRG. No.	001-0012
CHANGE	
ISS.	DESCRIPTION/DATE
1	1st. ISSUE 06-11-03

DRAWING NUMBER		001-0012
SHT	OF	A3

TITLE
**L.P.E. HUB ASSEMBLY
(PNEUMATIC CYLINDER)**

Corona Supplies
HOWLAND ROAD BUSINESS PARK, THAME, OXON, ENGLAND.

DRAWN	<i>L. Carter</i>
DATE	06-11-03

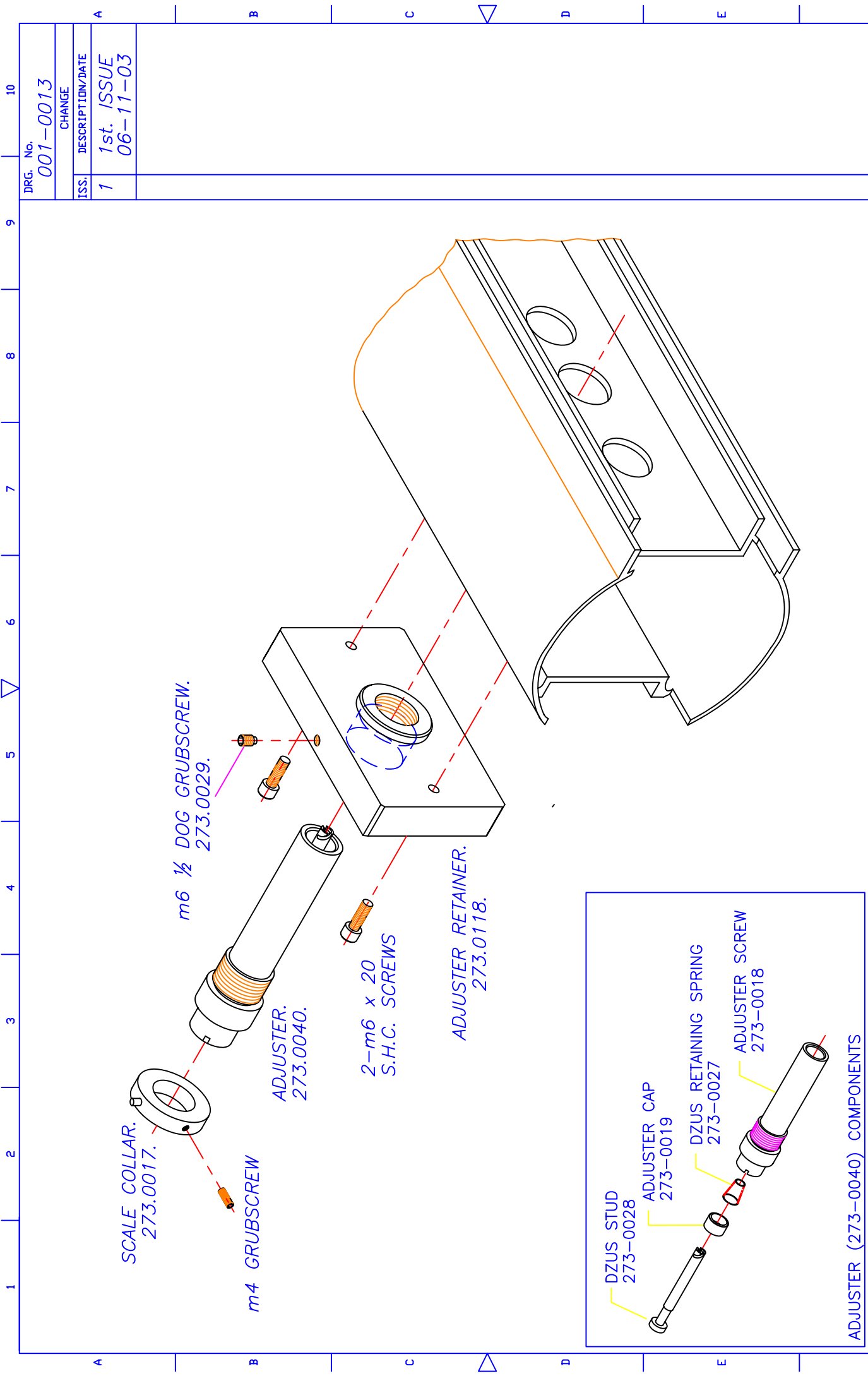

DRG. No. 001-0013	
CHANGE	
ISS.	DESCRIPTION/DATE
1	1st. ISSUE 06-11-03

DRAWING NUMBER 001-0013	
SHT	DF
	A3

TITLE
**L.P.E. ASSEMBLY
(GAP ADJUSTER)**

Corona Supplies

 HOWLAND ROAD BUSINESS PARK, THAME, OXON, ENGLAND.

DRAWN <i>M. Boasley</i>	DATE 06-11-03
----------------------------	-------------------------

ADJUSTER (273-0040) COMPONENTS

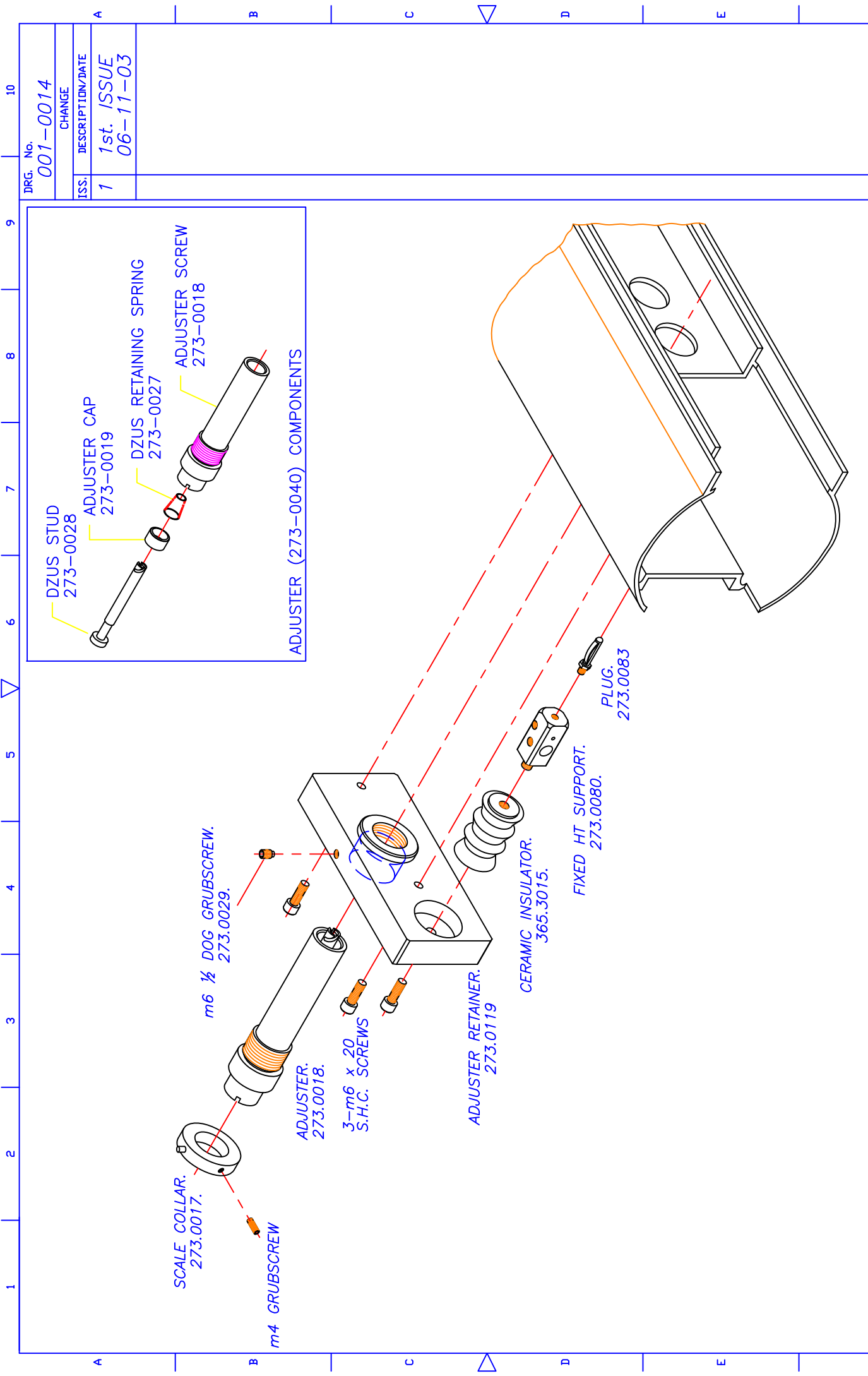

DRG. No.	001-0014
CHANGE	
ISS.	DESCRIPTION/DATE
1	1st. ISSUE 06-11-03

DRAWING NUMBER	001-0014
SHT	DF
OF	A3

TITLE
L.P.E. ASSEMBLY
 (GAP ADJUSTER / HT CONNECTION)



Corona Supplies
 HOWLAND ROAD BUSINESS PARK, THAME, OXON, ENGLAND.
 DATE 06-11-03

THE INFORMATION SHOWN ON THIS DRAWING IS CONFIDENTIAL AND MUST NOT BE COPIED REPRODUCED OR COMMUNICATED TO A THIRD PARTY WHOLLY OR IN PART WITHOUT THE WRITTEN CONSENT OF CORONA SUPPLIES ©20

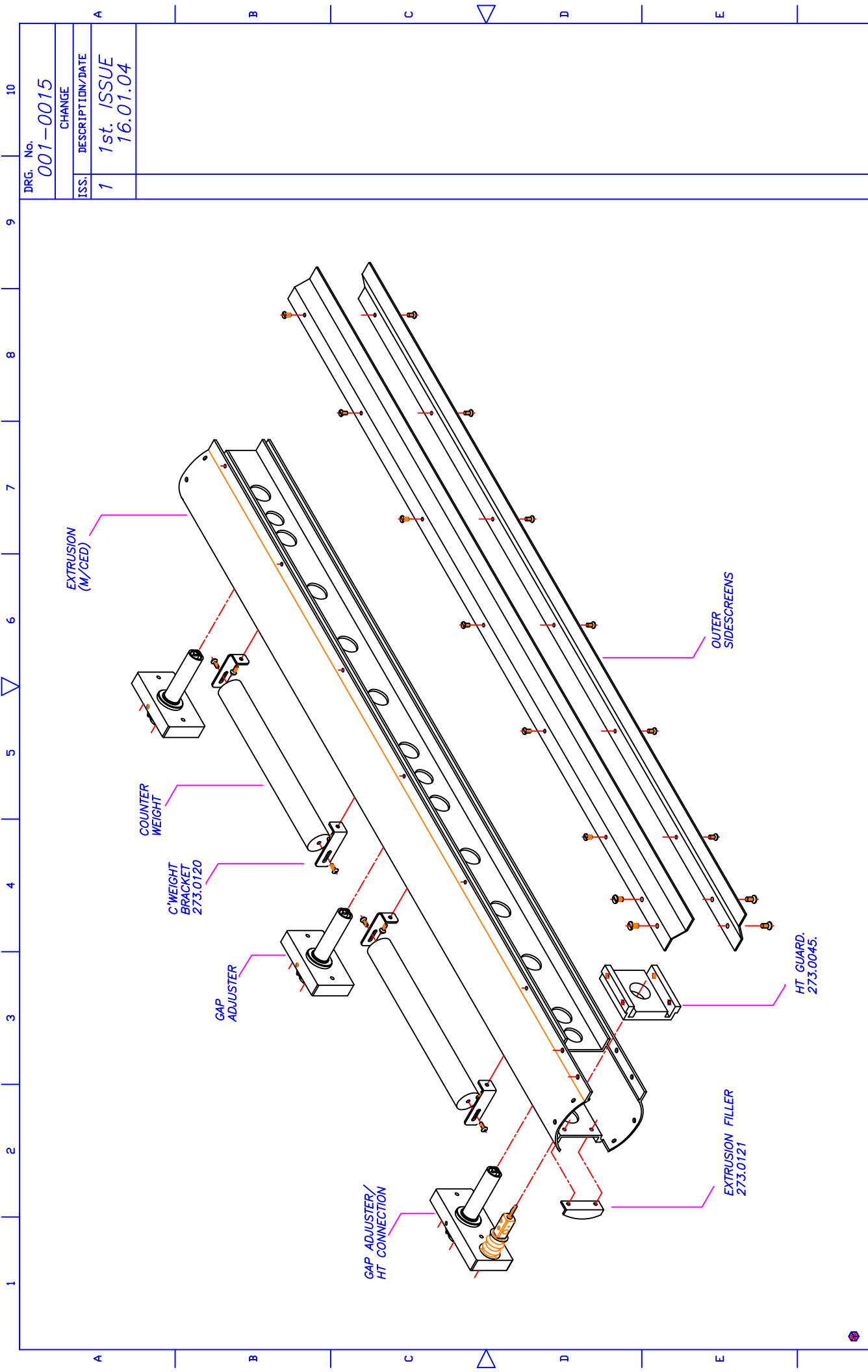

DRG. No.	001-0015
CHANGE	
ISS.	DESCRIPTION/DATE
1	1st. ISSUE 16.01.04

DRAWING NUMBER	001-0015
SHT	OF
	A3

TITLE
 (L.P.E. ASSEMBLY)
 EXTRUSION ASSEMBLY

Corona Supplies
 HOWLAND ROAD BUSINESS PARK, THAME, OXON, ENGLAND.

DRAWN	<i>L Carter</i>
DATE	16.01.04

THE INFORMATION SHOWN ON THIS DRAWING IS CONFIDENTIAL AND MUST NOT BE COPIED REPRODUCED OR COMMUNICATED TO A THIRD PARTY WHOLLY OR IN PART WITHOUT THE WRITTEN CONSENT OF CORONA SUPPLIES

ACCESS COVERS & DOORS (OPTION) (PRESSURISED UNITS installed in EX areas)

It is important to make sure all of the machine covers are correctly fitted so that the corona treater remains under positive pressure. A build up of contamination on the inside of the covers may also lead to contamination of the web if it was to come loose.

MONTHLY	6 MONTHLY
<p>Check covers and windows are correctly fitted and all fixing screws are in place.</p> <p>Check interlock switches operate correctly, are in a good condition and are securely fastened to the frame work.</p>	<p>Remove covers and remove any build up debris using a stiff brush.</p> <p>Clean viewing windows and replace any that are damaged or missing.</p>

ROLLS

Very little maintenance is required of the rollers and bearings. After a period of time the roll surface may become contaminated with dirt & material deposits which should be removed as described below. When handling or cleaning the rolls great care should be taken not to damage the silicon rubber or ceramic coating.
NEVER USE KNIVES NEAR SILICON OR RUBBER COATED ROLLERS

6 MONTHLY	YEARLY
<p>Check roll covering for signs of damage or build-up of contamination. Ceramic coverings can be cleaned with a light solvent. Silicon rubber coverings can be cleaned with a soap & water solution.</p> <p>Check rolls are rotating freely. If the rolls do not rotate freely check the air gap between the electrodes and roller to ensure the electrodes are not inhibiting the rolls rotation.</p> <p>Bearings should be checked and replaced if worn.</p>	<p>Check rolls are rotating concentrically. If the rolls are moving laterally in any axis the bearings may need replacing.</p> <p>Worn or damaged silicon sleeves should be replaced.</p>

INTERLOCKS

The interlock circuit should be checked regularly to ensure correct and safe operation of the corona system. Failure to carry out these checks may leave the system unsafe.

Monthly

Check each interlock switch is working correctly and is securely fastened to the corona treater framework, door or window. When an interlock switch is opened the corona should stop immediately. Switches are fitted to opening doors & windows, electrode extrusions and the ozone extraction & pressurisation (pressurised units only) system. There may also be an emergency stop button mounted close to the corona treater station.

SEE "CIRCUIT DIAGRAM - TREATER INSTALLATION" DRAWING THAT WAS SUPPLIED WITH YOUR CORONA SYSTEM FOR MORE INFORMATION.

OZONE EXTRACTION SYSTEM

The ozone extraction system not only removes the ozone produced during the corona treatment process but also cools the electrodes during operation. It is important to keep the extraction system running efficiently to avoid over heating of the electrodes which will lead to premature failure and to eliminate the risk of ozone leaking back into the work area. If the corona treater is pressurised (EX area) the fan and ducting should also be checked as described below.

6 Monthly

Check for blockages in the extraction ducting and fan impellor. Stray material can be easily sucked into the extraction system and fan, reducing the air flow.

Check for leaks and damaged ductwork, especially in the ducting from the fan to atmosphere as this is under positive pressure. Ozone is heavier than air and will fall back to the ground from damaged or leaking duct work above head height.

Warranty & Aftersales Service

All our products are warranted for 12 months from invoice date within the underwritten conditions:

Complete replacement of any mechanics or electrics parts not properly functioning.

This replacement will be accomplished only to the following condition:

- a)** We are quickly informed by phone or email about a fault on our machinery, specifying equipment plate data and if possible component characteristic and identifier.
- b)** The faulty and/or malfunctioning material to be returned to our office within 30 days from receiving new spare parts. If within this time we don't receive the faulty part we will be obliged to charge the required.
- c)** Will be verified by our technicians that the component is truly faulty. Otherwise if the damage is caused by improper equipment use or there is evidence of tampering with tools and/or unauthorized personnel or the equipment has not been used in accordance with the instruction manual, we will not be liable for damages and parts will be charged.
- d)** The freight will be charged to customer.

The warranty doesn't cover technician's costs for replacement and/or spare parts installation supplied, so this cost will be charged and invoiced in the usual way.

THIS EQUIPMENT WAS SUPPLIED TO YOU BY:



Corona Supplies Ltd
for all your corona needs

Unit G
Howland Road Business Park
Thame
Oxon
OX9 3GQ. UK.
Telephone: +44 (0) 1844 261779
Fax: +44 (0) 1844 358187
E-mail: sales@coronasupplies.co.uk

**FOR FURTHER ASSISTANCE, PARTS OR SERVICE
PLEASE CONTACT US IMMEDIATELY**

THANK YOU